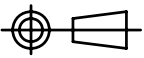

REV.	REVISION RECORD	DATE	REV.	REVISION RECORD	DATE
A			C		
B			D		

NAME	EPC-19SMD (海鷗PIN) (10P)	MATERIAL	LCP(E4008)	SCALE	2/1	ANGLE:	±1°
DRAWING NO.	HY S1901-1	PIN MATERIAL	CP WIRE	UNIT	m/m	REV.:	A
UL REC.:94V-0	PIN TENION LOAD: 0.8kg MIN		 <p>信詠塑膠工業股份有限公司 HSIN YUNG PLASTIC INDUSTRIAL CO.,LTD. TEL:886-2-29953711 FAX:886-2-29990010 信詠塑膠電子廠 HSIN YUNG PLASTIC ELECTRONICS FACTORY TEL:0769-6632011 FAX:0769-6635843</p>				
TOLERANCES	0<L≤10:±0.1 10<L≤20:±0.15 20<L≤40:±0.2						
	PIN PITCH:±0.2 WALL THICKNESS:±0.05						